

Installation Guide

TS1000 Plus series

Version: 1.0

Revision History

Revision	Date	Author	Reviewer	Description
V1.0	01/08/2024	Yang Kaijin		Original Document

1 Installation Requirements

1. It is recommended that the device be installed on a level and solid floor. If the floor is uneven or not strong enough to hold the device in place, resurface the floor or use a pedestal mount to alleviate the change problem.
2. Avoid using the device directly in open air or wet, corrosive environments where rain, moisture, or corrosive materials may impact its lifespan. Use it only if the device is explicitly rated for waterproofing.
3. Make sure the device's grounding wire is securely connected. Differentiate between strong and weak power setups to prevent potential harm to personal safety and unforeseen incidents.
4. After installation, inspect the grounding wire, connectors, junctions of the connecting line, and moving parts to ensure secure connections. Tighten any loose nuts, screws, or fasteners promptly to prevent long-term gate failure.

2 Installation Environment

Refer to the provided figure to identify the installation position based on the device's size and space requirements. When installing against a wall, leave a 100mm space to allow for opening the top cover during commissioning and maintenance. Maintain a 100mm distance between two devices if multiple channels are present.

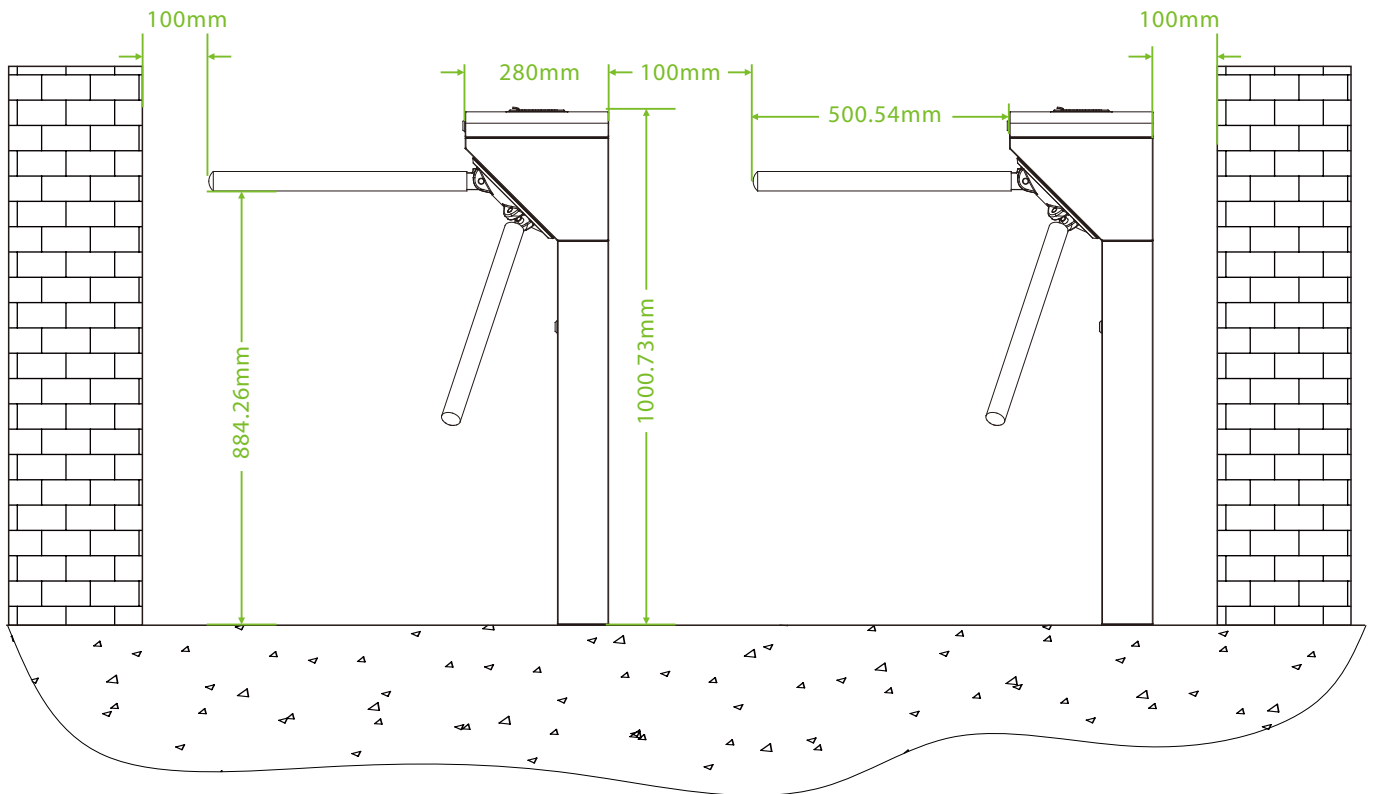

3 Preparation

Before installing the device, make sure you have the following items:

- **Screwdriver:** For removing or installing screws on the device.
- **Pencil:** To mark the device size and screw hole locations.
- **Electric Drill:** To drill holes according to the marked screw holes.
- **Wrench:** To secure the M12 expansion screw on the device.
- **Tapeline:** To measure dimensions during installation.
- **Hex Wrench:** For removing or installing screws on the device.
- **Cutting Machine:** For cutting the road and laying cables.

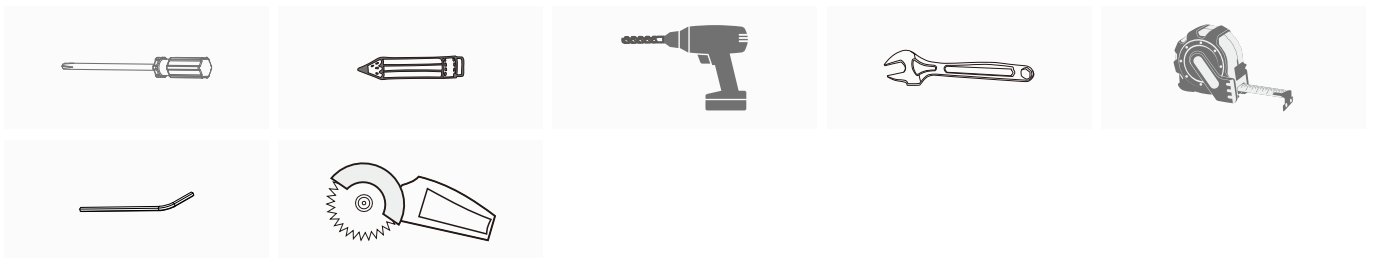

Note: Except for the hex wrench, ensure all other tools are provided by you.

4 Installation

1. After checking the list to ensure all devices and items are correct, transport the device to its installation location.

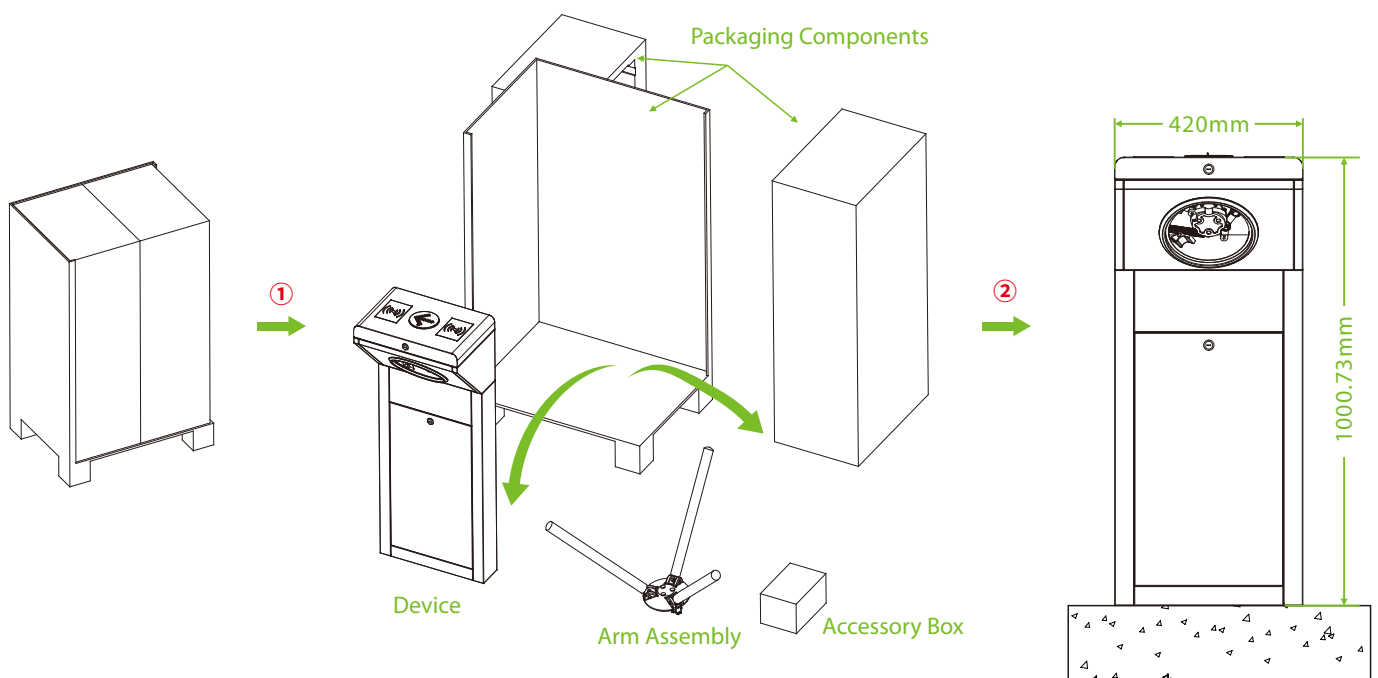

2. Use the key to open the device chassis and then remove the covers.

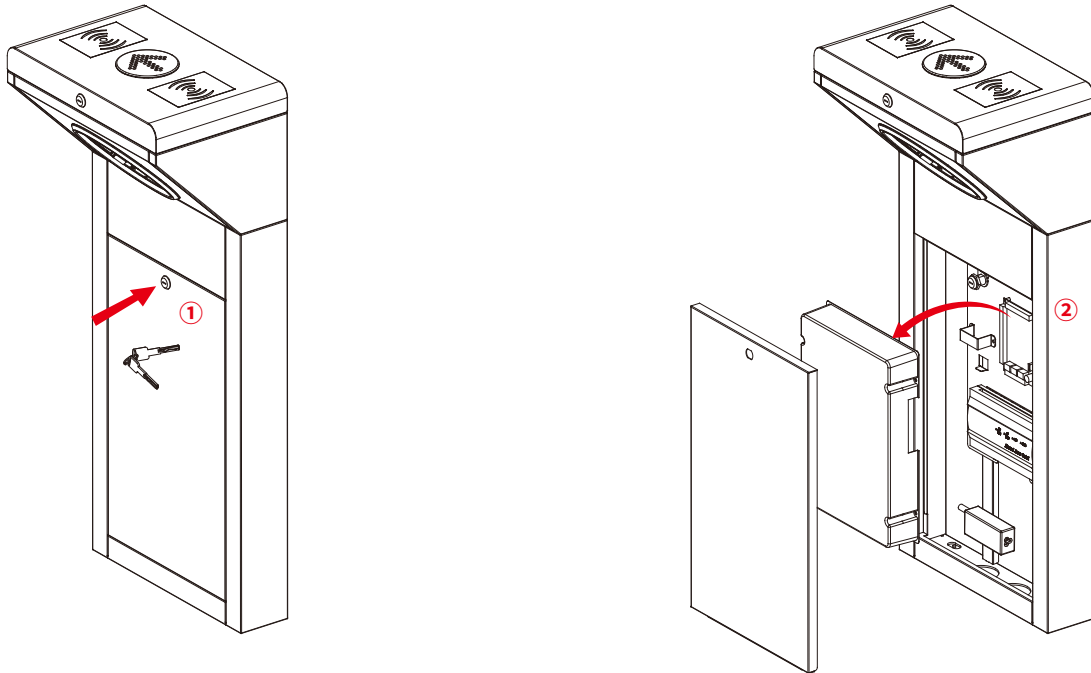

3. Use a pencil to mark down the screw holes, wire holes, and conduits of the device.

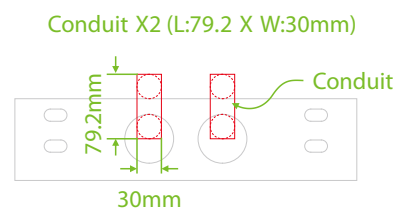
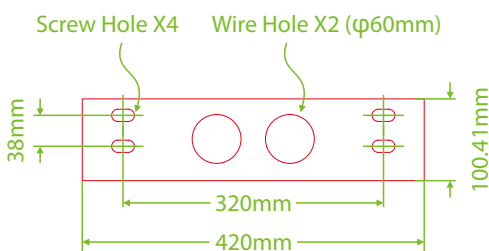
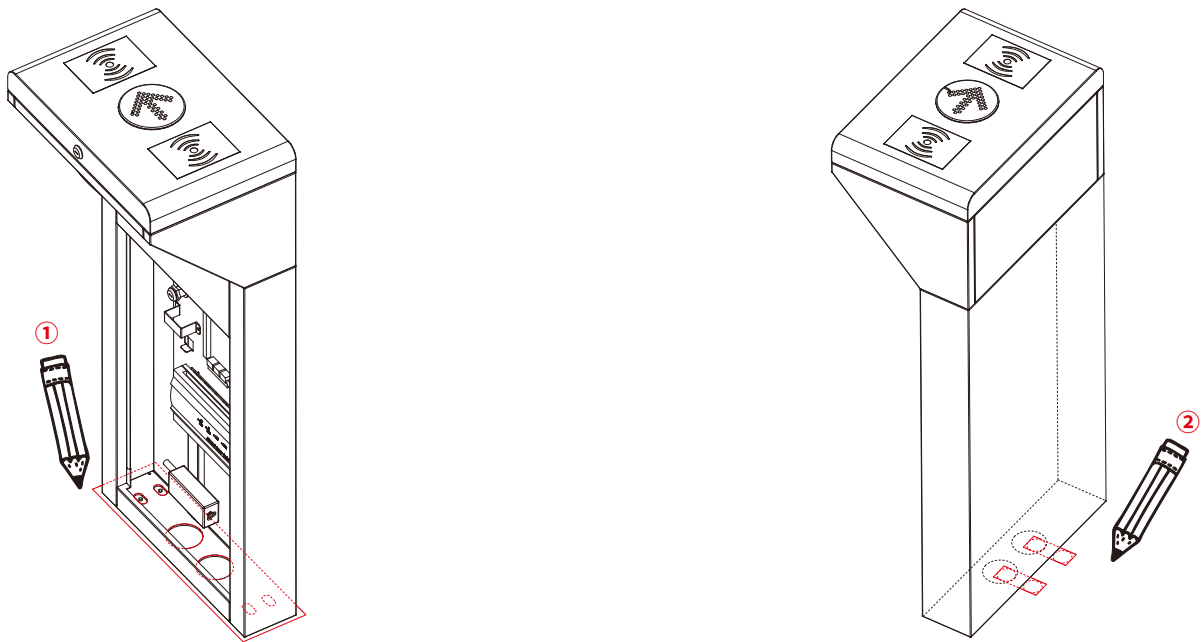

Note: For the safety of the device and future maintenance, when installing, please ensure to encase the power cable and network cable within a PVC pipe with a diameter of 20mm. The conduit diameter should exceed 20mm; this guide suggests using 30mm as an example.

4. Take out the device and use an electric drill to create holes based on the markings.

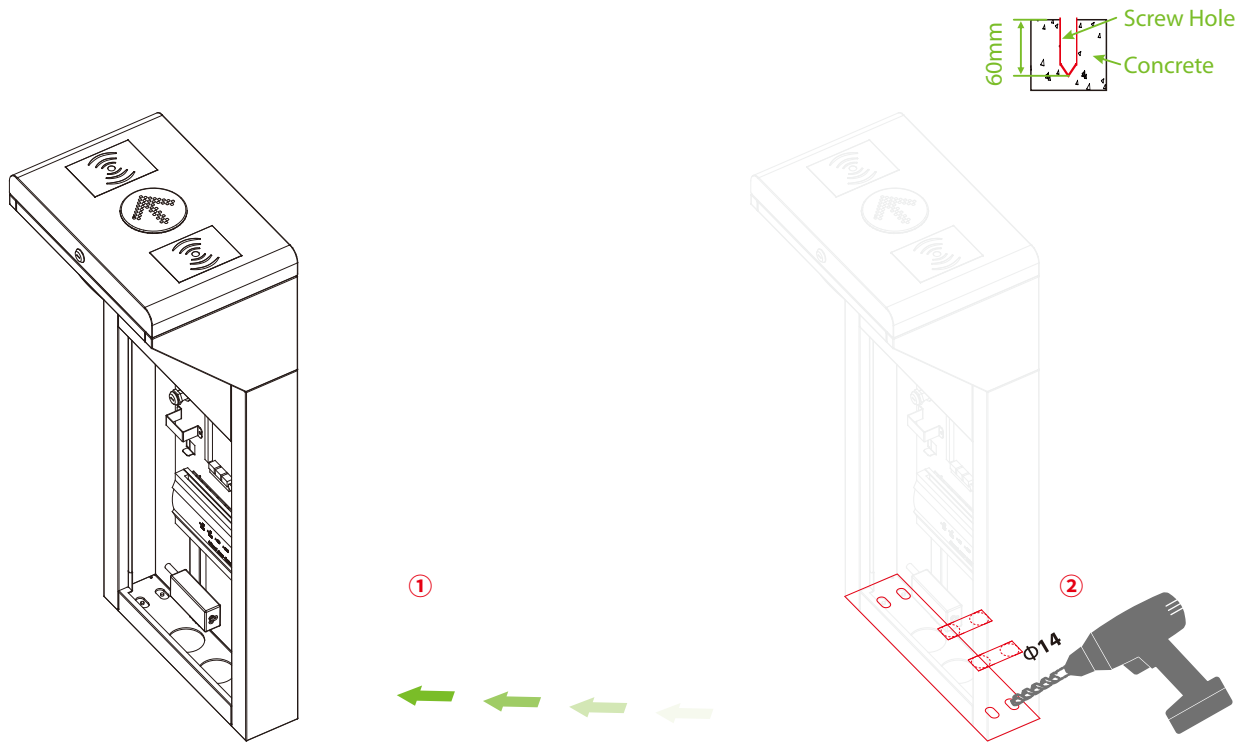

5. According to the mark of the device, use a cutting machine to create two conduits on the device that is 30mm wide, 79.2mm length and 100mm deep.

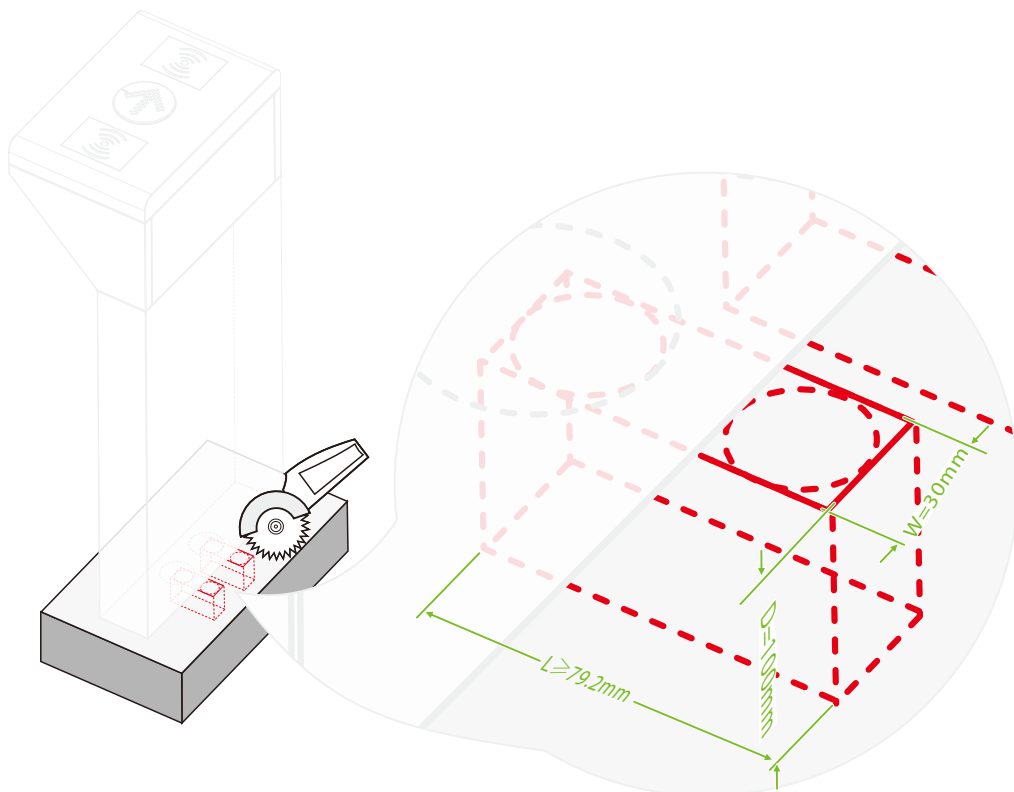

6. After drilling, clean up debris and dust, then reposition the device at the installation site. Verify if the drilled holes and conduits align with the marks on the device.

①

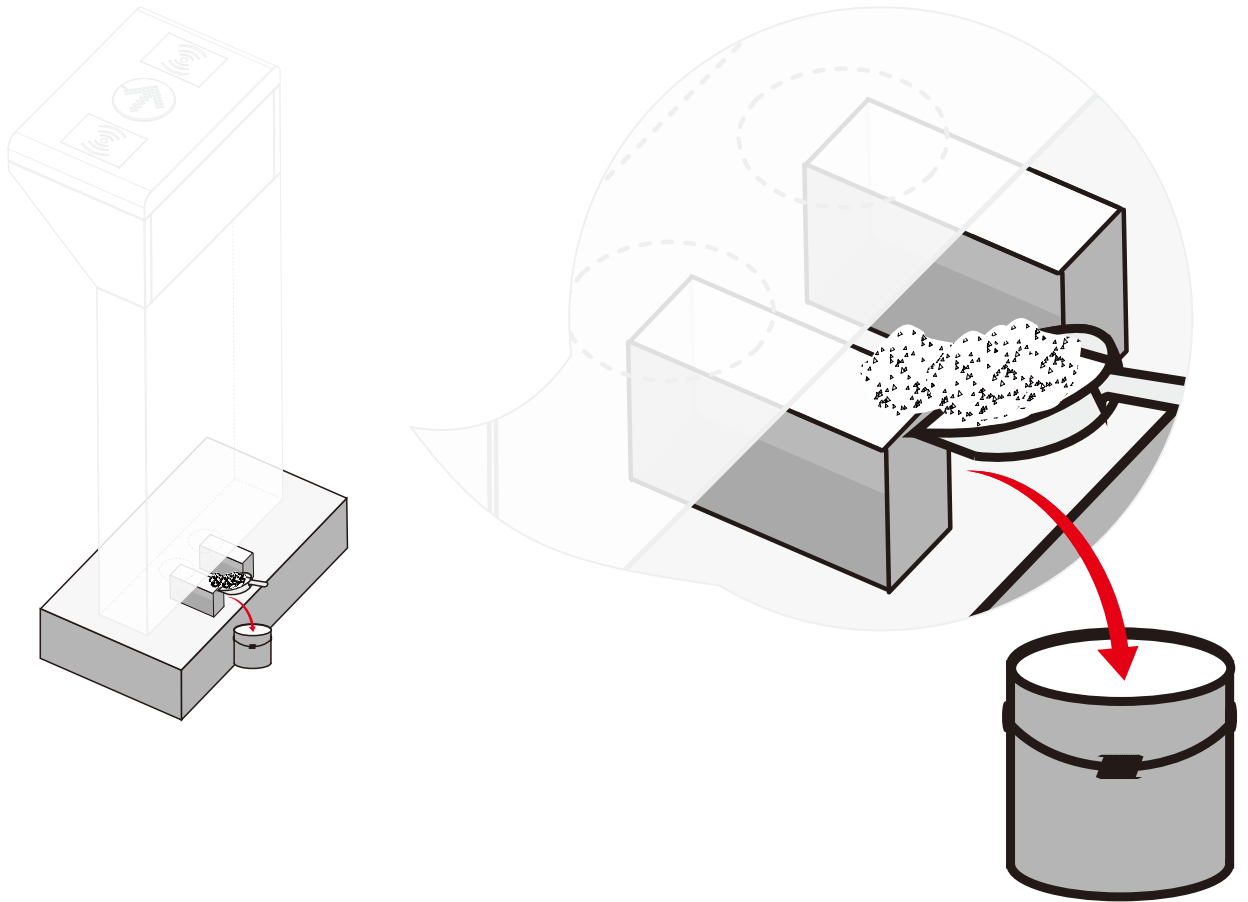

②

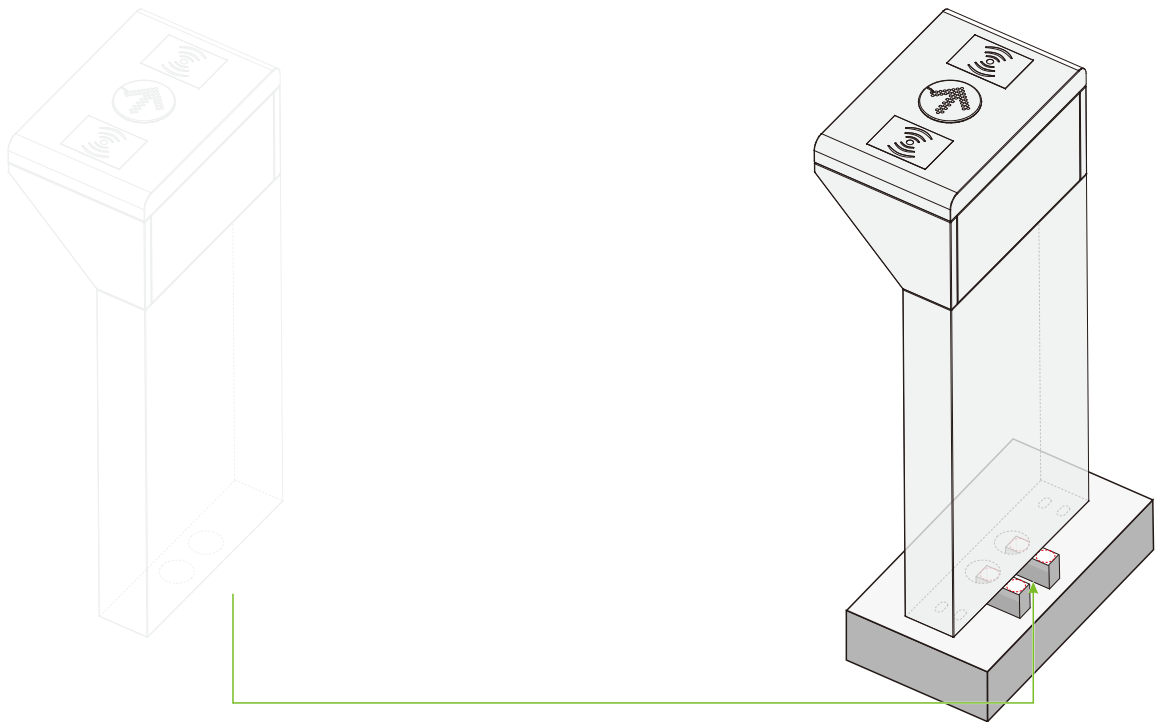

7. Place the 20mm diameter PVC pipe into the conduit, thread the power cable, Ethernet cable, and fire signal cable through the PVC pipe to connect the power supply, controller, and fire alarm. Test all device functions for normal operation, disconnect the power supply once confirmed, and fill the conduit with concrete.

φ20mm PVC Pipe Power Cable Ethernet Cable Fire Signal Cable

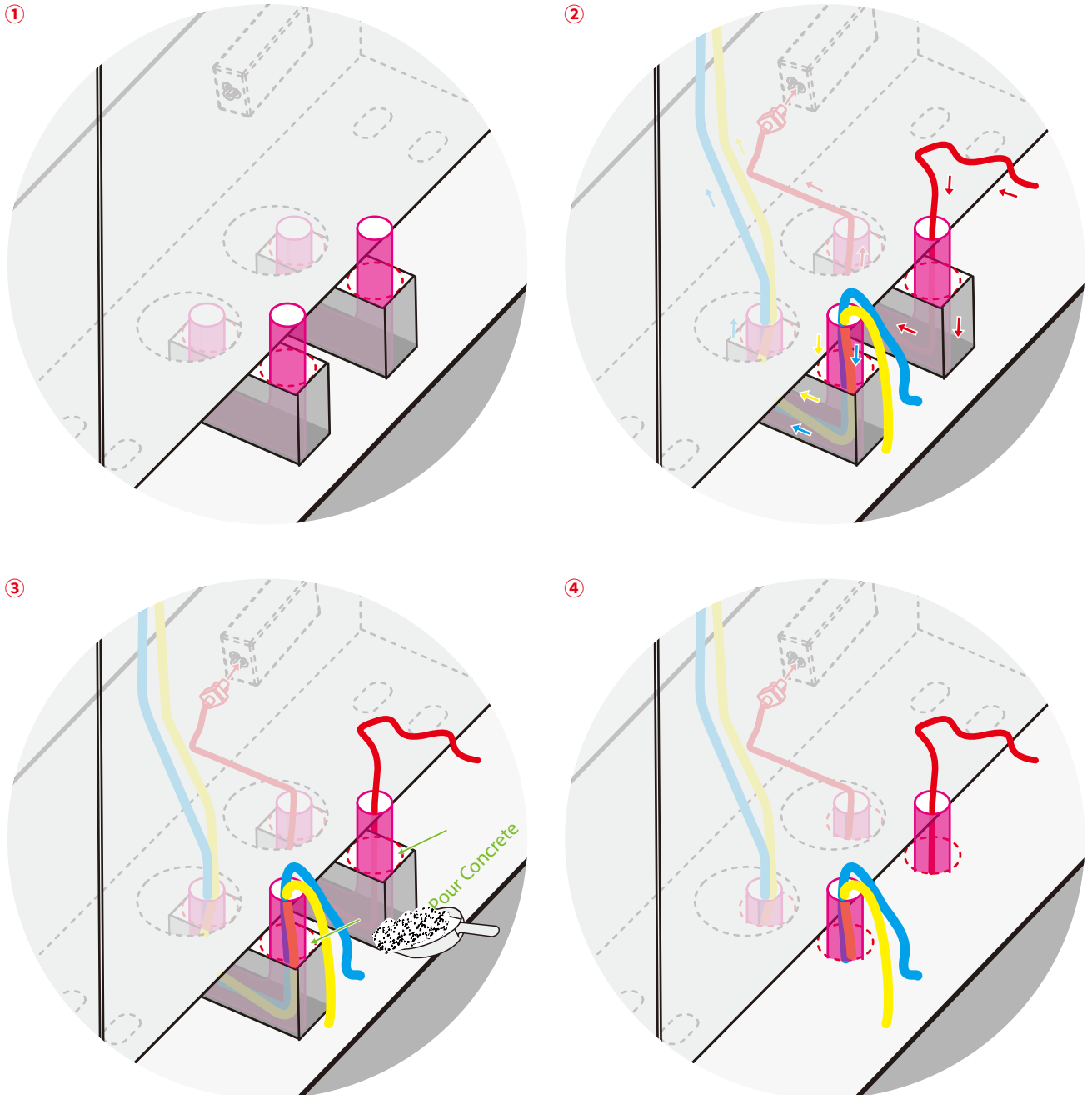

Note:

- 1). Separate strong and weak power lines during installation.
- 2). After completing the test, disconnect the device's power supply, and avoid operating the equipment with electricity.
- 3). The conduit depth should be a minimum of 100mm, and the height of the exposed PVC pipe above the ground should exceed 100mm. Ensure the exit bends back to prevent water from entering the wire pipe.

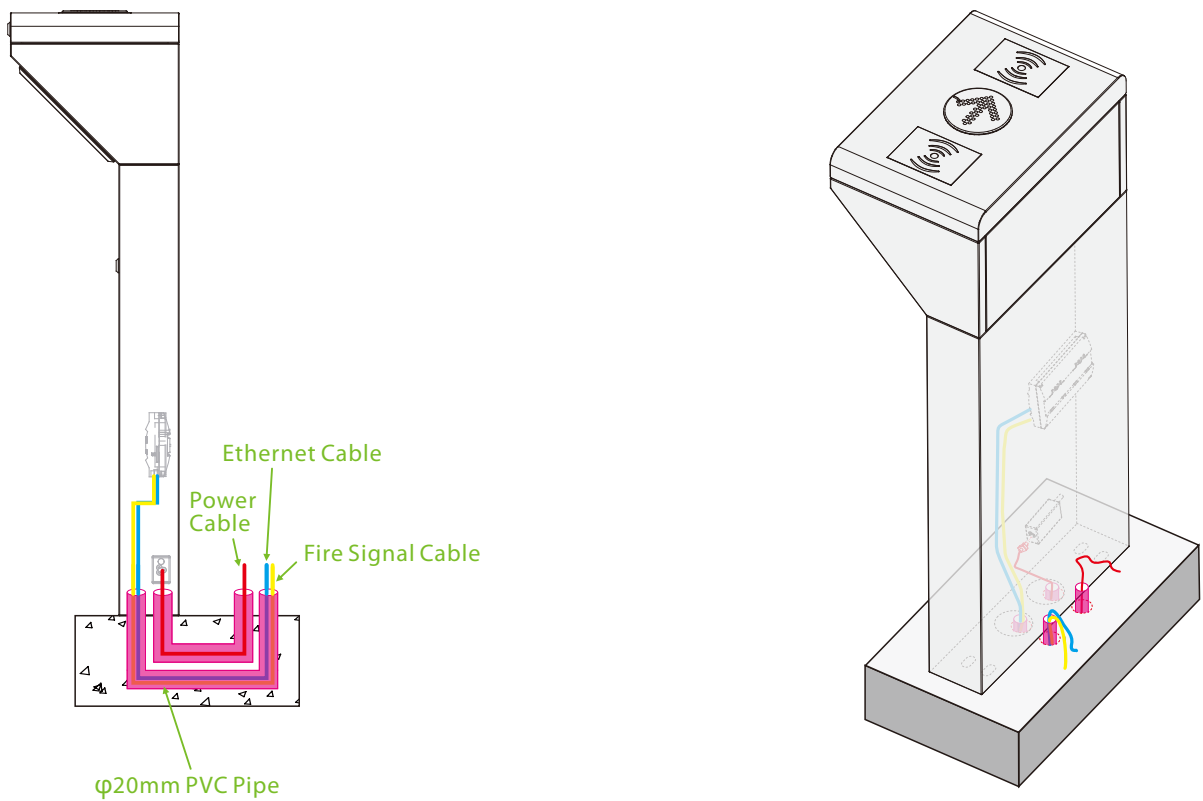

8. Align the device with the drilled holes. Next, insert the bolts and secure them using a wrench. Finally, add the washers and the nuts, and tighten them securely with a wrench.

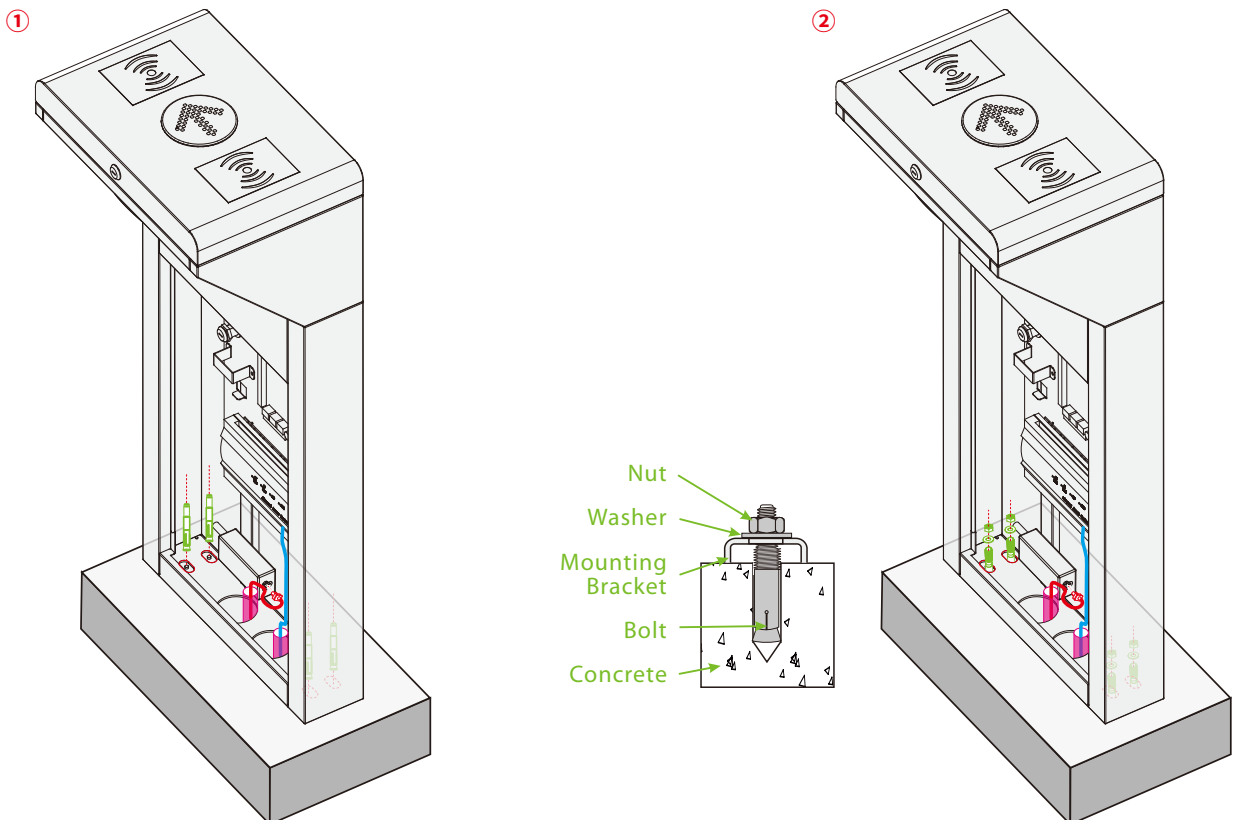
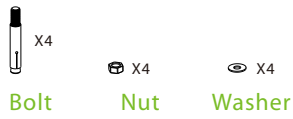

9. Install the chassis covers and use the key to lock it.

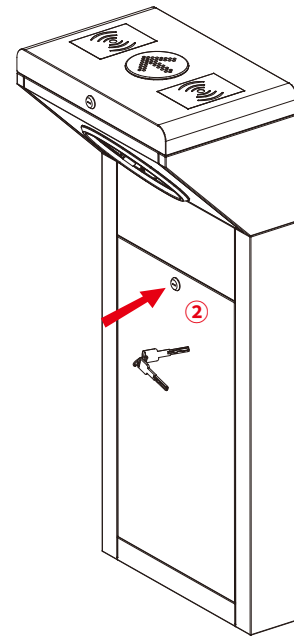
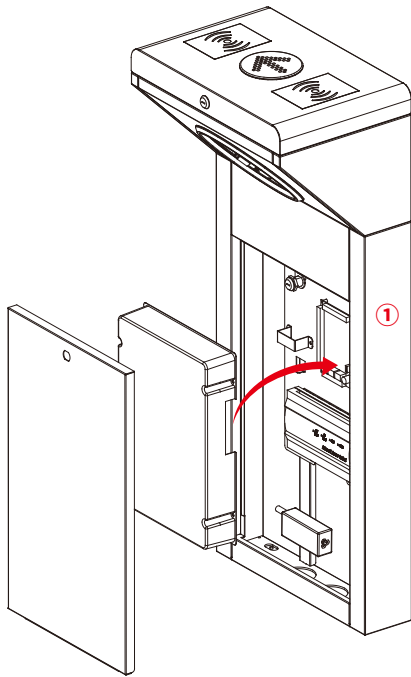

10. Use the key to open the top lid of the device.

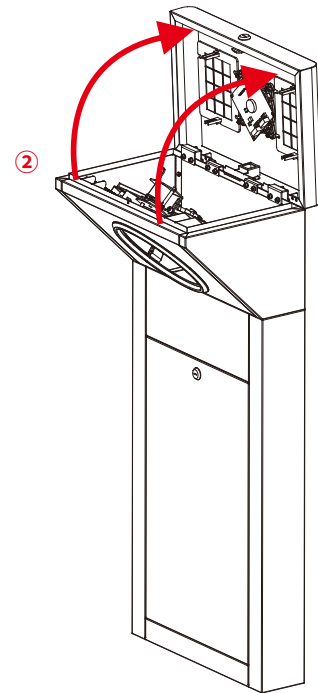
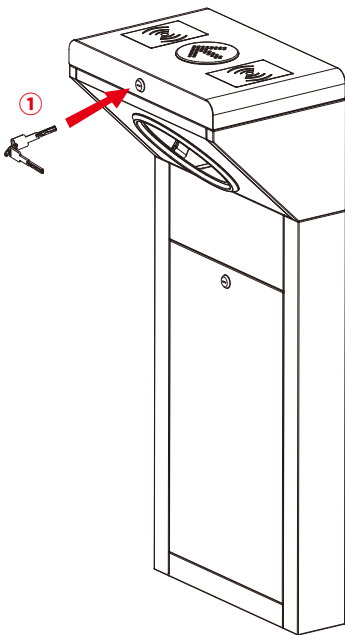

11. Align the arm assembly with the internal chassis assembly, and then secure it with the screws.

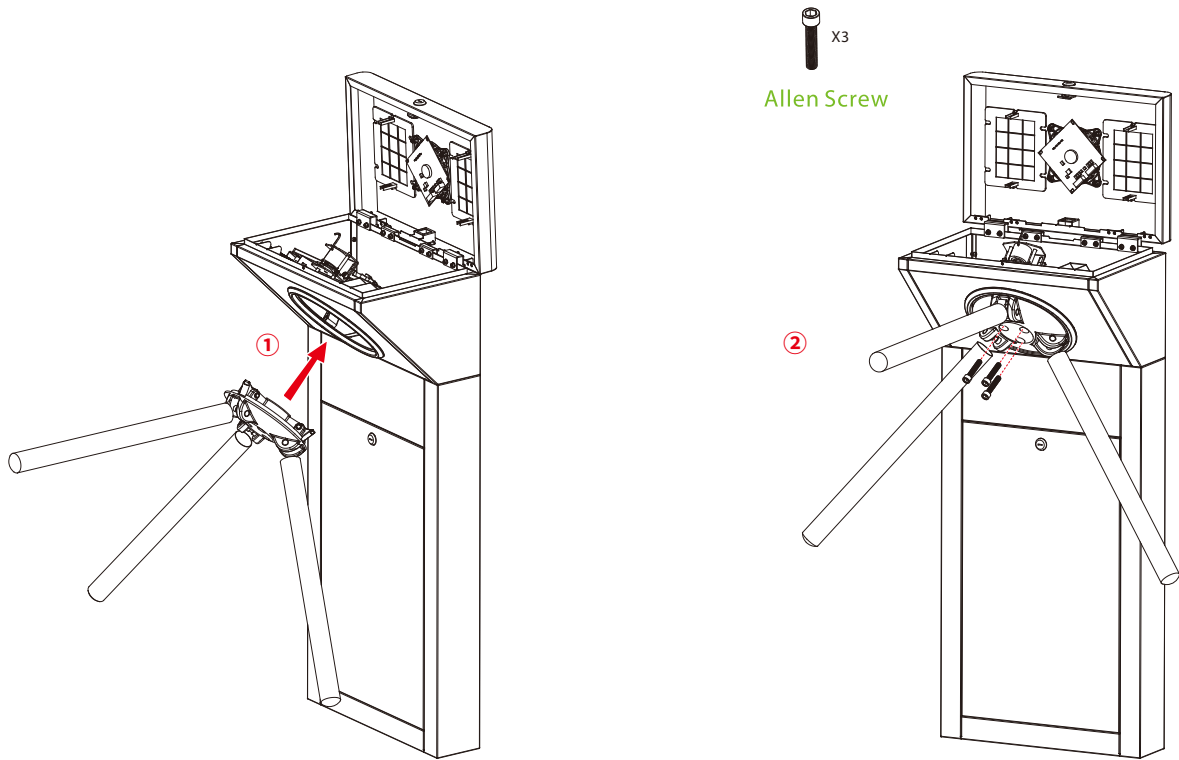

12. Close the top lid and lock it.

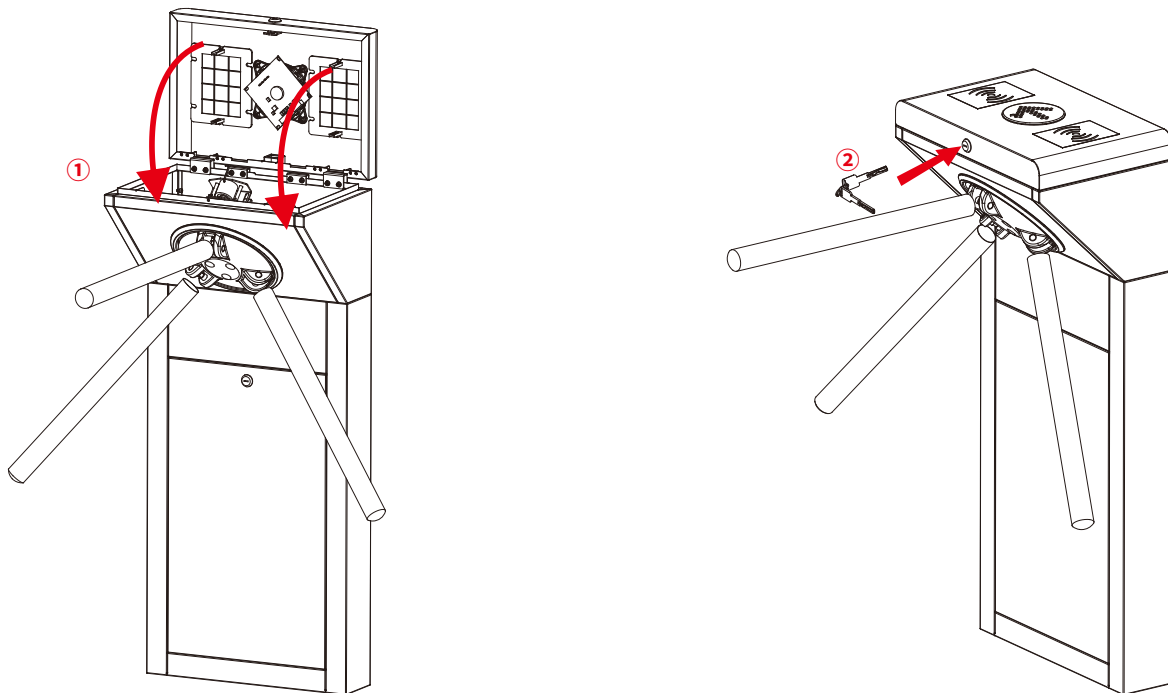

13. We suggest marking a warning line on the floor after installation. This serves as a reminder for users to wait outside the marked area until the previous user completes the verification process and passes through the device.

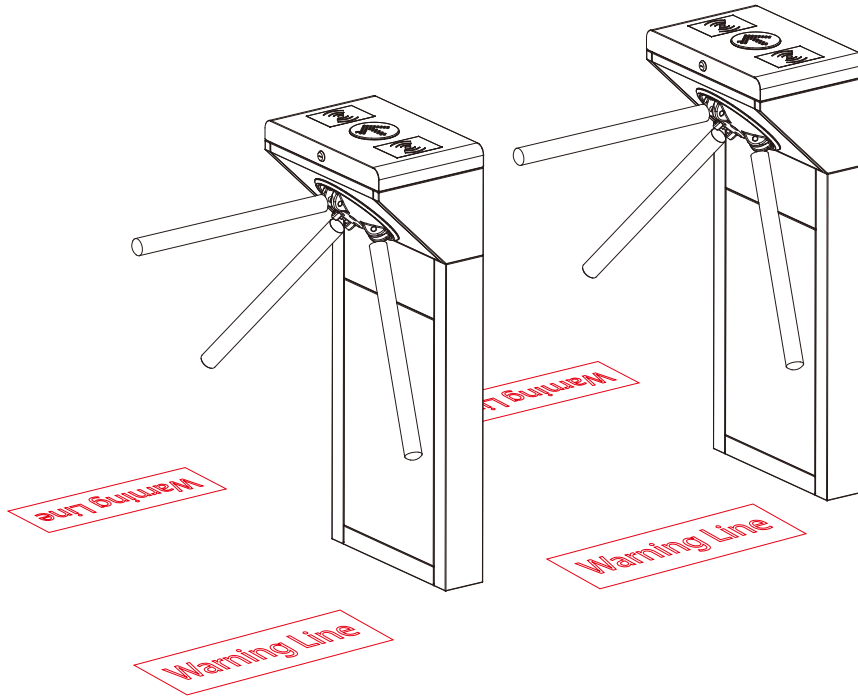

5 Wiring Diagram

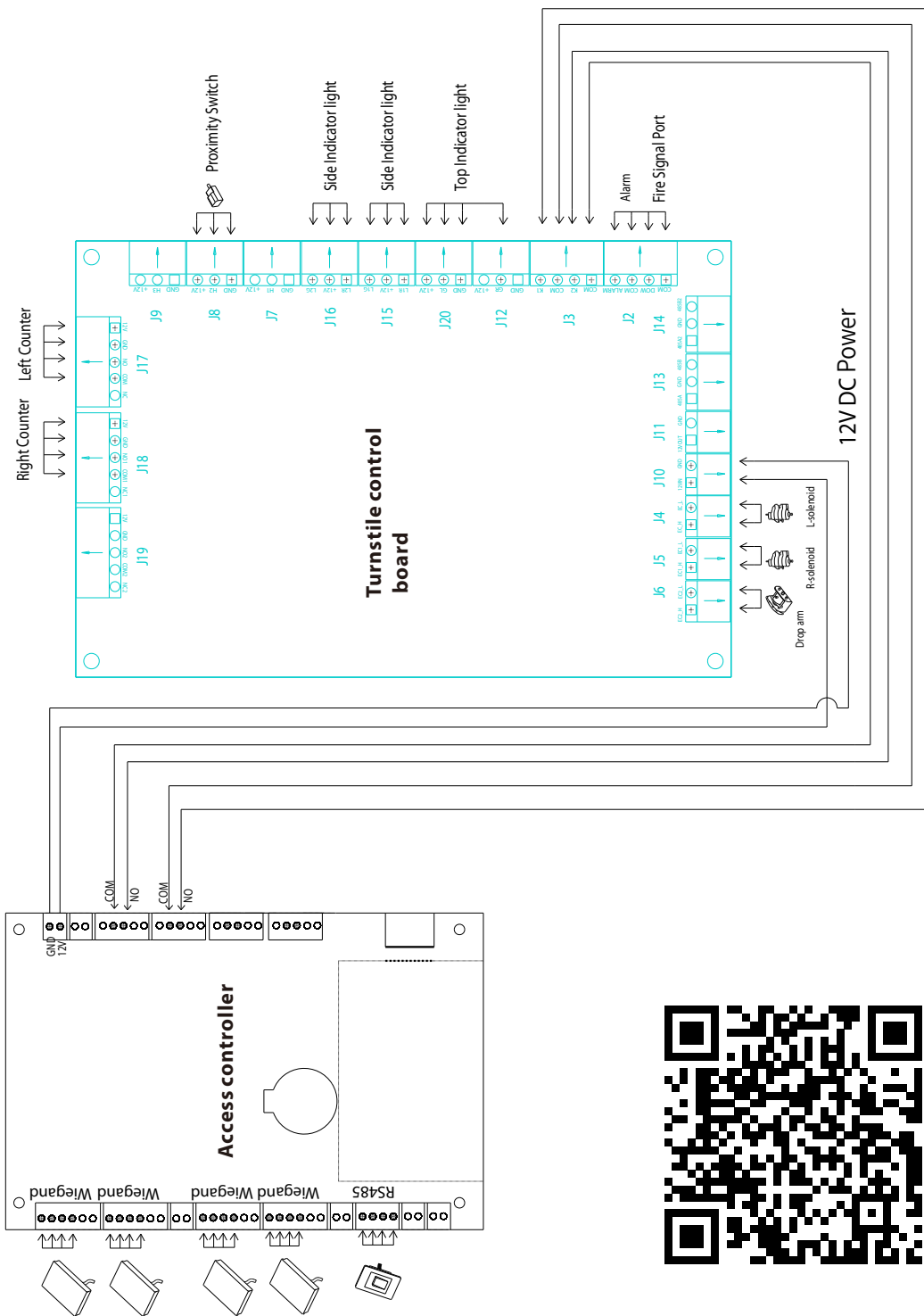

Scan the QR code to view the manual

