

Quick Start Guide

AC01-F28H-12

Version: 1.0

1 Overview

Front

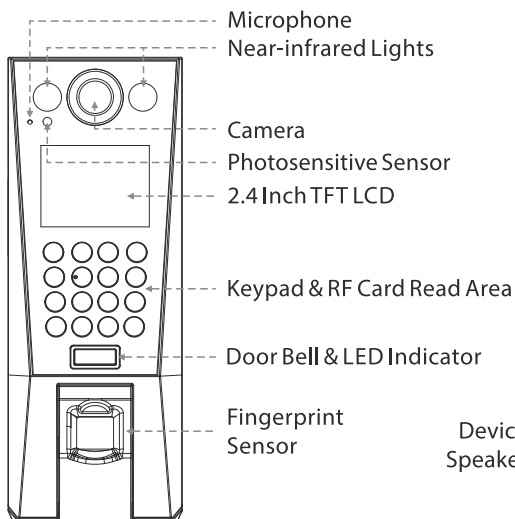

Side

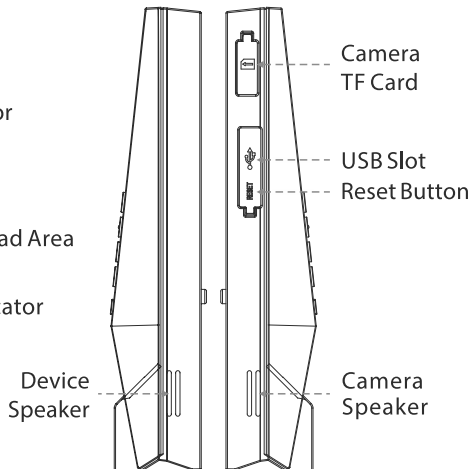

Back

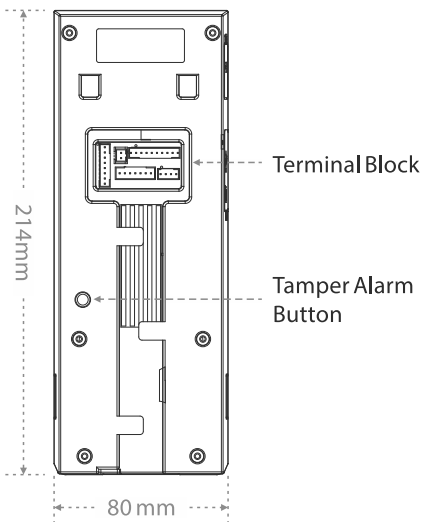

Bottom

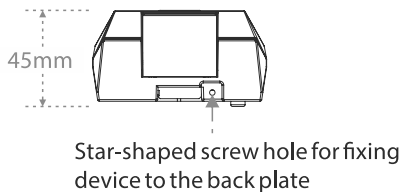

Terminal Block:

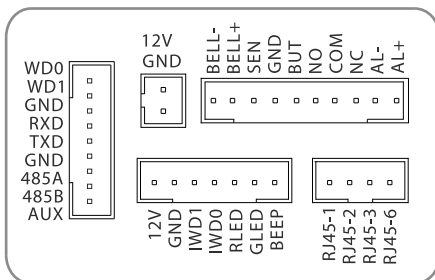

Installation Environment

Please refer to the following recommendations for installation.

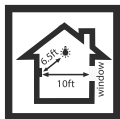

KEEP DISTANCE



AVOID GLASS REFRACTION



AVOID DIRECT SUNLIGHT AND EXPOSURE



AVOID USE OF ANY HEAT SOURCE NEAR THE DEVICE

Device Installation

Before the installation, please connect the cables to the connectors.

- 1) Attach the mounting template to the wall and drill holes accordingly.
- 2) Fix the back plate on the wall using the provided mounting screws.
- 3) Mount the device on the back plate.
- 4) Secure the device and back plate.

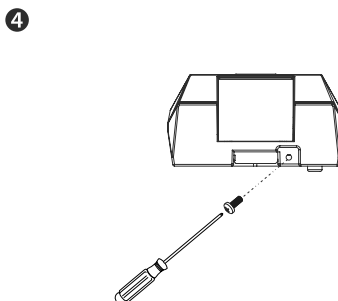
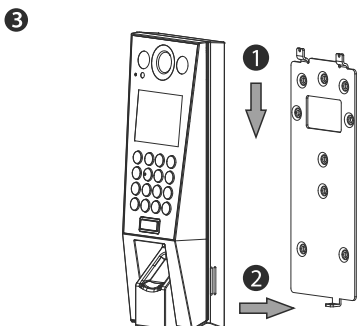
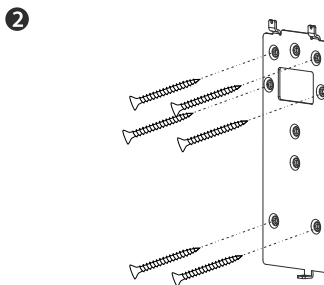
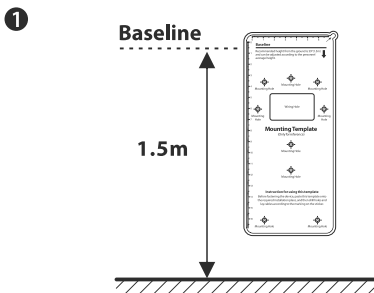

Standalone Installation

Access Control

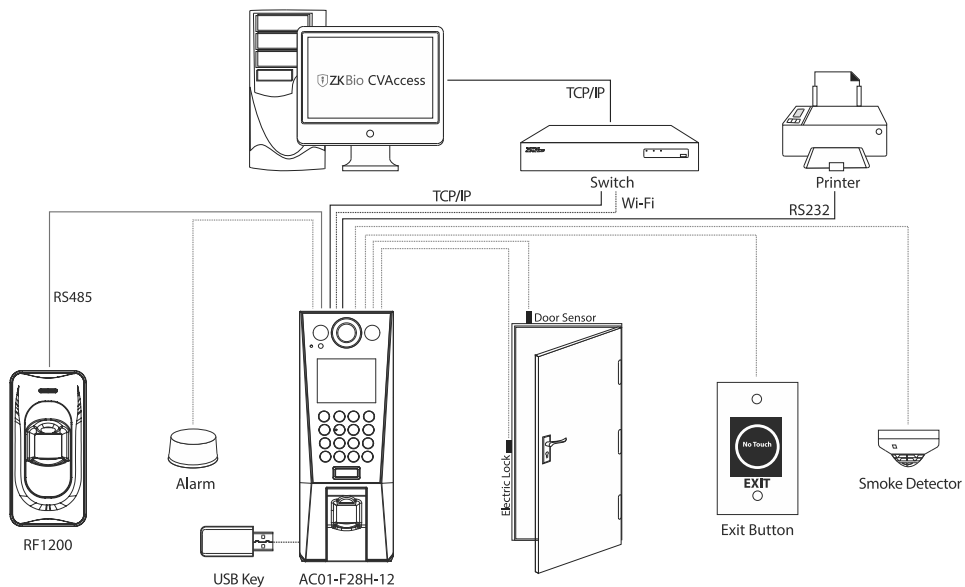

IVA & Video Intercom

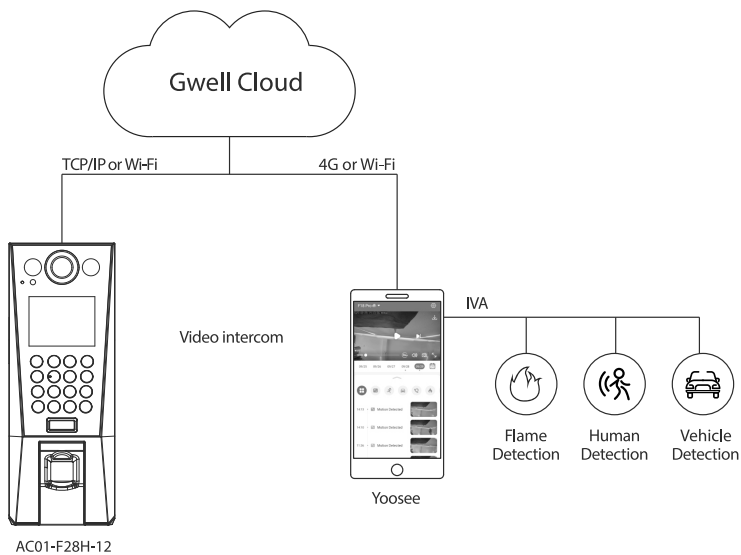

Lock Connection

The system supports Normally Opened Lock and Normally Closed Lock.

The NO LOCK (normally opened at power on) is connected with 'NO' and 'COM' terminals, and the NC LOCK (normally closed at power on) is connected with 'NC' and 'COM' terminals. Take NC Lock as an example below:

1) Device not sharing power with the lock:

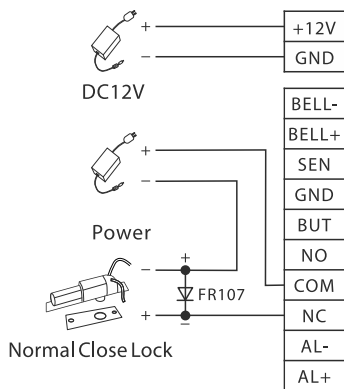

2) Device sharing power with the lock:

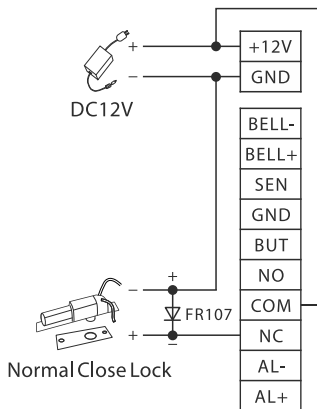

Door Bell & Door Sensor & Exit Button & Alarm Connection

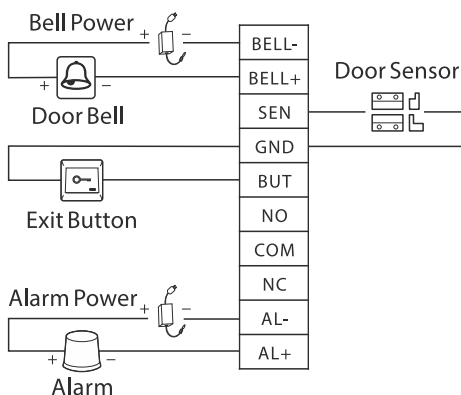
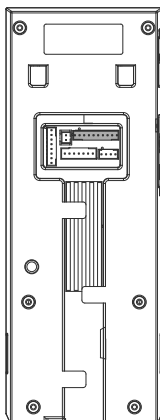

DM10 Connection

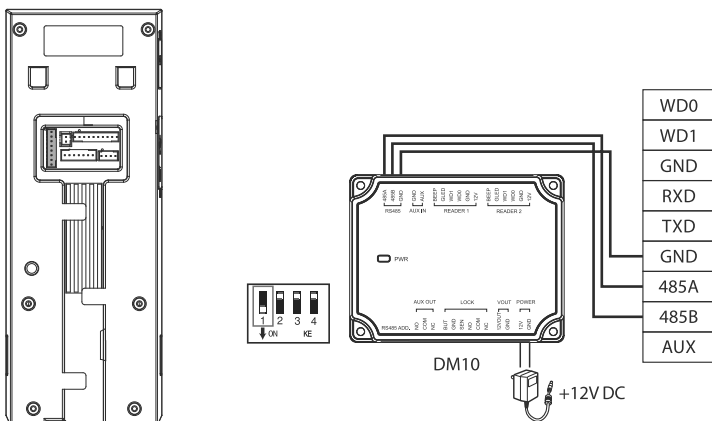

Notes:

1. Press **M/OK** on the initial interface. Select **COMM. > Serial Comm > Serial Port**, then set the serial port to **DM10**.
2. When connecting to DM10, slide the DIP switch position 1 to the ON position.

RS485 Reader and RS232 Connection

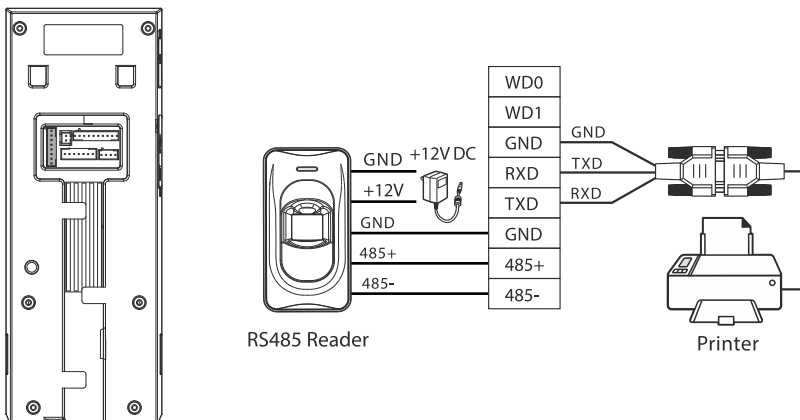

Note:

Press **M/OK** on the initial interface. Select **COMM. > Serial Comm > Serial Port**. When connecting a reader, set the serial port to **Primary Unit**. For an RS-232 printer, set Serial Port to **Print Function**.

Controller Connection

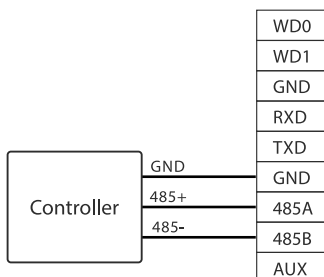
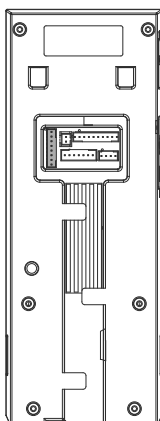

Note:

Press **M/OK** on the initial interface. Select **COMM.** > **Serial Comm** > **Serial Port**, then set the serial port to **OSDP Secondary Unit**. The device will be used as a secondary device.

Wiegand Reader Connection

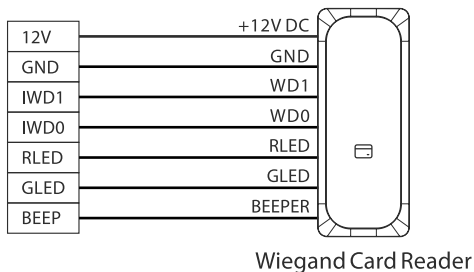
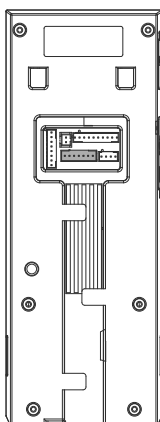

Power Connection

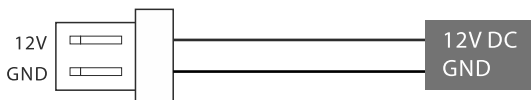
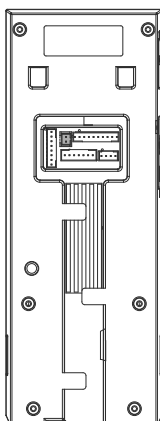

Recommended power supply:

- 1) $12V \pm 10\%$, at least 1A.
- 2) To share the power with other devices, use a power supply with higher current ratings.

Ethernet Connection

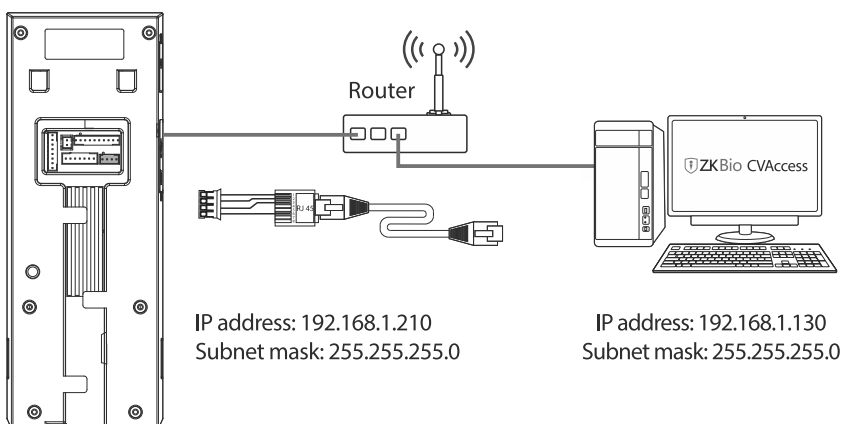

The device defaults to enabling DHCP functionality and does not support disabling DHCP. It can only obtain an IP address and connect to the network by connecting to a router.

Note: The IP address should be able to communicate with the ZKBio CVAccess server, preferably in the same network segment with the server address.

User Registration

When there is no super administrator set in the device, press **M/OK** to enter the menu. After setting the super administrator, the system will request for the administrator's verification before entering the menu. For the security purpose, it is recommended to register a super administrator at the first time you use the device.

Method 1: Registering on the Device:

Select **User Mgt.** > **New User** and press **M/OK** to register a new user. Settings include entering user ID and name, registering fingerprint, password and card, setting user role.

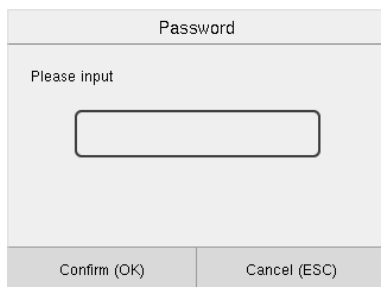
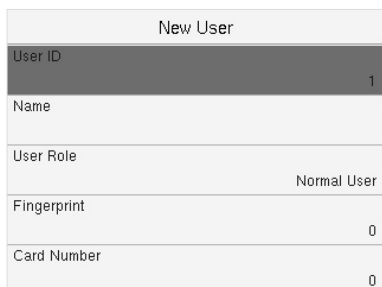
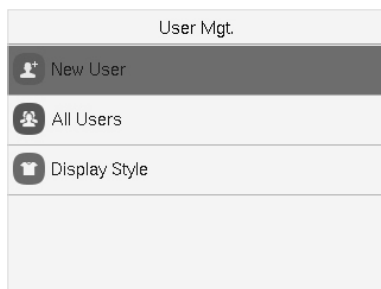
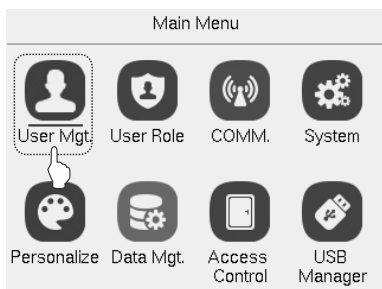

Method 2: Register on ZKBio CVAccess software:

Please set the IP address and cloud service server address in the Comm. Menu option on the device.

1. Click **[Access]** > **[Device]** > **[Search]** > **[Search]** to search the device on the software. When an appropriate server address and port is set on the device, the searched device displays automatically.

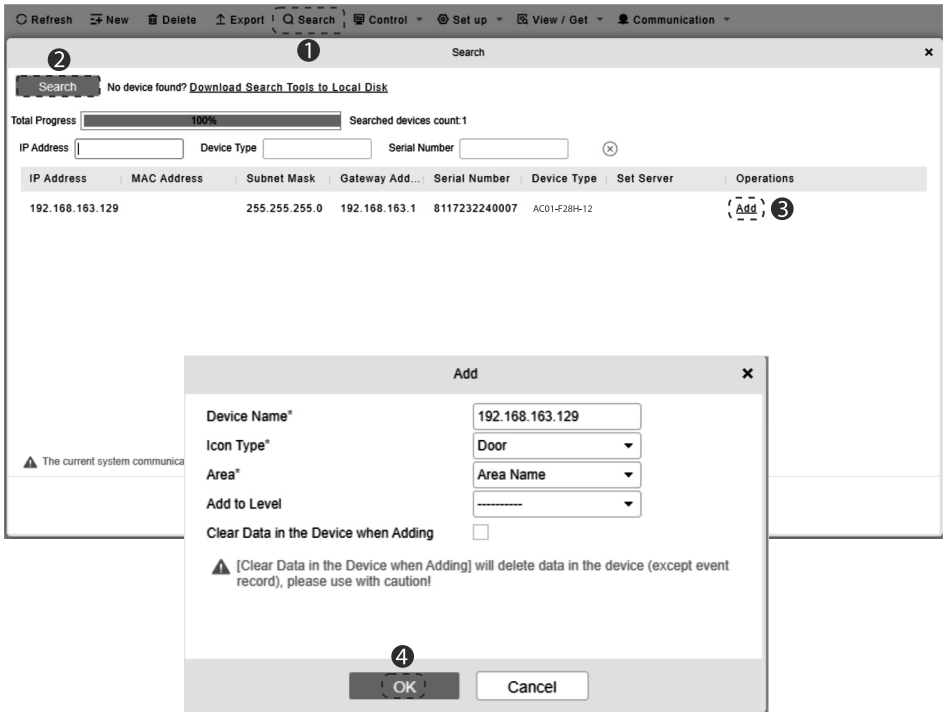

2. Click **[Add]** in operation column, a new window will pop-up. Select Icon type, Area, and Add to Level from each drop down list and click **[OK]** to add the device.
3. Click **[Personnel]** > **[Person]** > **[New]** and fill in all the required fields to register new users in the software.
4. Click **[Access]** > **[Device]** > **[Control]** > **[Synchronize All Data to Devices]** to synchronize all the data to the device including the new users.

For more details, please refer to the ZKBio CVAccess User Manual.

Method 3: Register on the phone:

Please set the IP address and cloud service server address in the Comm. Menu option on the device.

1. Click [**Personnel**] > [**Parameters**], enter "http://Server address: Port" in the QR Code URL bar. The software will automatically generate a QR code. Scan the QR code or login onto "http://Server address: Port/tokenAdreg" by the mobile phone to register users.

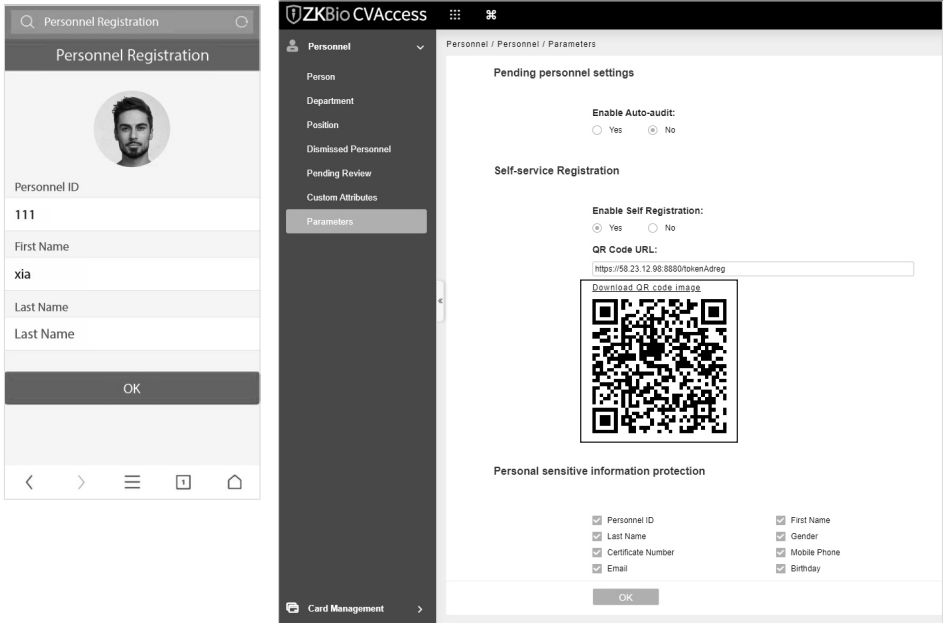

2. The users will be displayed in [**Personnel**] > [**Pending Review**]. Click the [**Review**] option and assign a department, then click [**OK**] to successfully add the user.

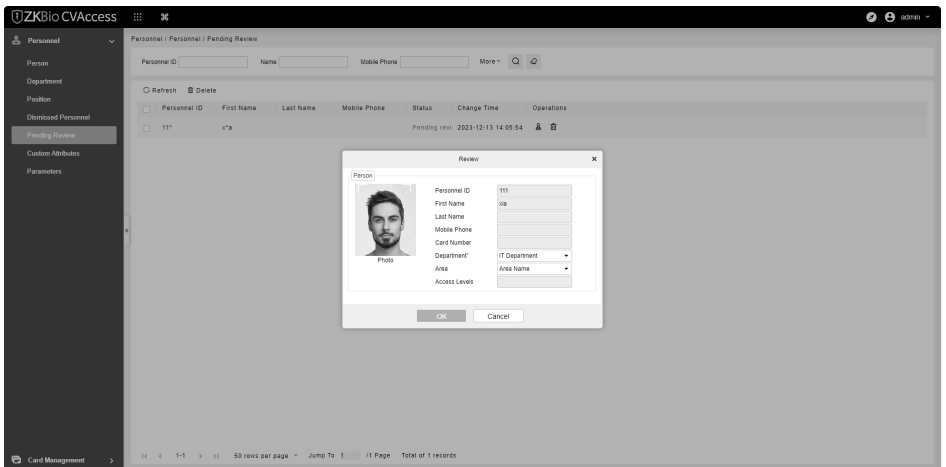

Ethernet and Cloud Server Settings

Tap on **M/OK > COMM. > Ethernet** to set the network parameters. If the TCP/IP communication of the device is successful, the icon  will be displayed in the upper right corner of the standby interface.

Tap on **M/OK > COMM. > Cloud Server Settings** to set the server address and server port. For example, set the IP address and port number of the server after the software is installed. If the device communicates with the server successfully, the icon  will be displayed in the upper right corner of the standby interface.

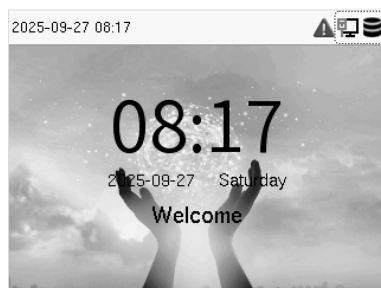
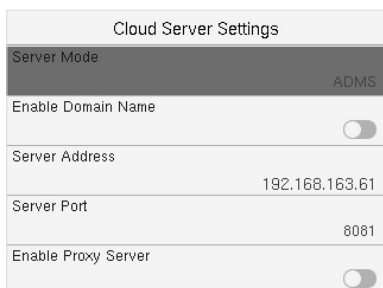
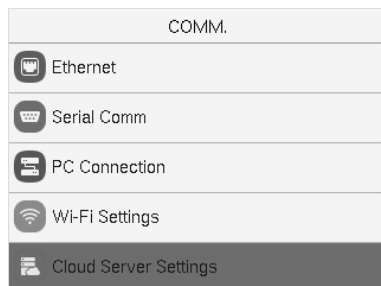
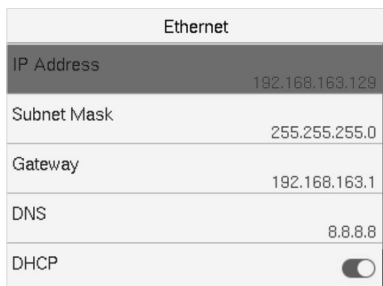
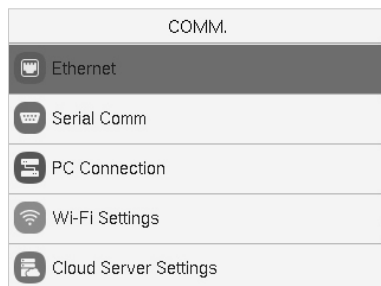
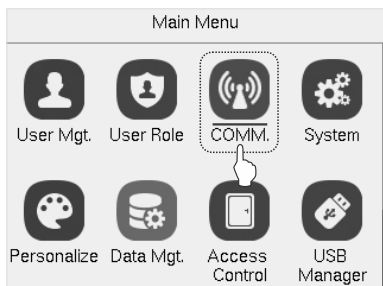

Notes:

During the process of pairing the device with the ZKBio CVAccess / ZKBioTime8.0 software.

Server Address: Set as the IP address of the ZKBio CVAccess / ZKBioTime8.0 server.

Server Port: Set as the Adms service port of ZKBio CVAccess / ZKBioTime8.0.

Configuring Wi-Fi

Tap on **M/OK > COMM. > Wi-Fi Settings** to configuring Wi-Fi. When Wi-Fi is enabled, select the searched network. Enter the password, and select **Connect to Wi-Fi (OK)**. The connection succeeds, with icon  displayed on the status bar. You can also select **Add Wi-Fi Network** to add Wi-Fi manually.

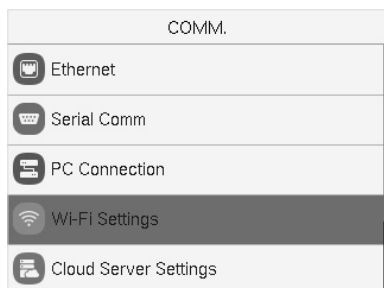

Notes:

The AC01-F28H-12 can only use DHCP to obtain dynamic IP address ; static IP configuration is not supported. The dynamic IP address assigned via DHCP (over Ethernet or 2.4 GHz Wi-Fi) must have direct access to the public Internet. Without Internet access, the device cannot communicate with Gwell Cloud.

Device Type Setting

Tap on **M/OK > System > Device Type Settings** to configure the Device Type Settings.

Note: After changing the device type, the device will delete all the data and restart, and some functions will be adjusted accordingly.

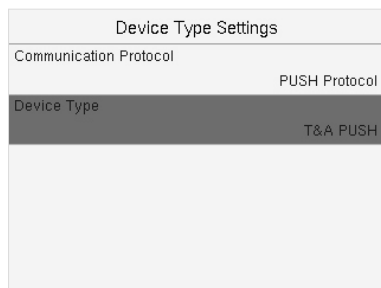
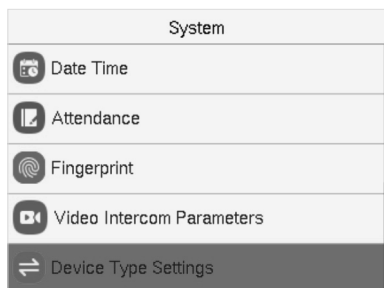

USB Manager

Tap on **M/OK** > **USB Manager** to upload or download data between device and the corresponding software through a USB disk.

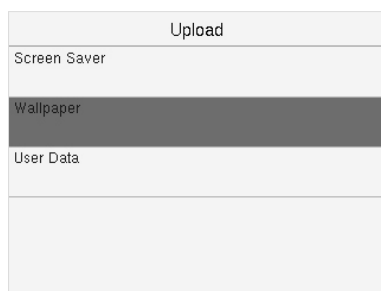
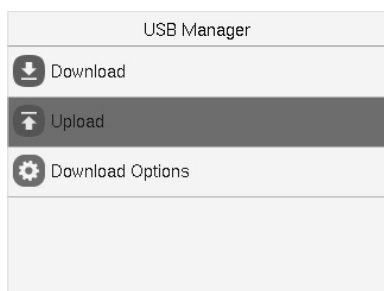

Notes:

- 1) Create a folder named **"Wallpaper"** in the root directory of your USB drive. Place the wallpapers you wish to upload into this folder.
- 2) Name each image as **"Wallpaper+number,"** such as **Wallpaper8**. The number must not exceed **Wallpaper45**.
- 3) Acceptable image formats are **.jpg, .bmp, .png, or .jpeg**. Each image must not exceed **2MB** in size.
- 4) The USB drive's file system must be **FAT32**; otherwise, the device will be unable to recognize its contents.

Print Settings

Tap on **M/OK** > **Print** to set printing information and functions. Devices with printing function can print attendance records out when a printer is connected.

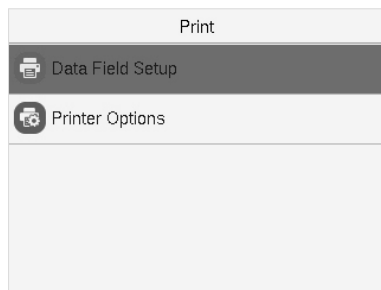
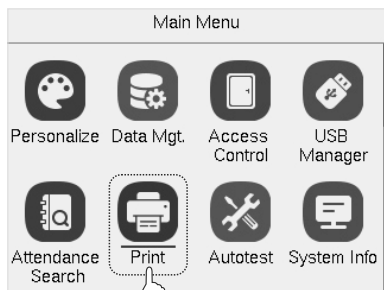

Remarks: To turn on the Paper Cut function, it is required to connect the device with a printer with paper cutting function, so that the printer will cut papers according to the selected printing information when printing.

Connect to the Yoosee App

Step 1: Download the Yoosee App

Method 1: Search for 'Yoosee' in your app store.

Method 2: Scan QR code to download Yoosee App.



Step 2: Register Account

Method 1: Click '**Register**', enter phone/email, follow app instructions to complete registration and click **Login**.

Method 2: Choose a supported provider (e.g., WeChat / Line / Facebook / Apple Account). Then, authorize the request and complete registration. Tap **Login** if prompted.

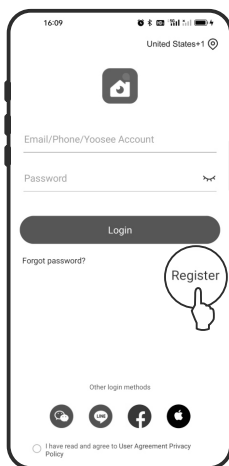

Notes:

- 1) When mobile number registration is unavailable in your selected country/region, only email registration is supported.
- 2) Data services are not interconnected across different registration regions. Please select the correct region for registration.

Step 3: Add the Device to the App

1. Power on the device. Wait about 30 seconds until the startup tone plays.
2. Ensure that both the device and your phone connect to Wi-Fi. You can configure Wi-Fi for the device by pressing the **M/OK** button > **COMM.** > **Wi-Fi Settings**.
3. Then press **M/OK** button > **System** > **Video Intercom Parameters** > **QR Code Binding** to display the device QR code. As shown in the figure below.

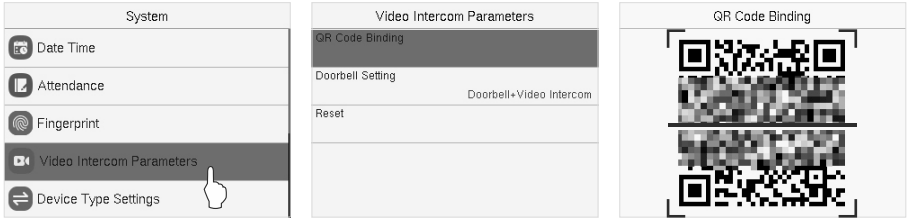

4. Open the Yoosee app, tap the ⊕ icon in the upper-right corner, and scan the device's QR code.
5. Follow the prompts on the app interface to add the device until you hear the device voice prompt stating "Device added successfully."

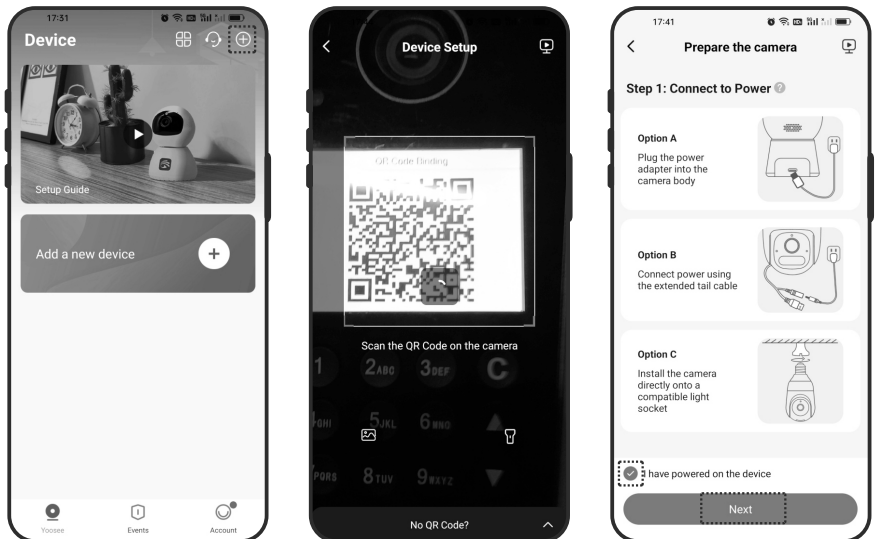

Notes:

- 1) Using AC01-F28H-12 as an example, one account can bind up to 300 devices.
- 2) Shared devices can be shared with up to 10 users.
- 3) Online video preview for devices supports up to 2 simultaneous viewers.

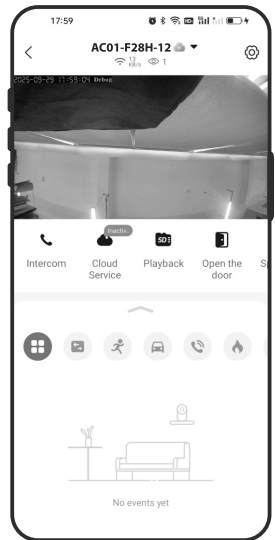
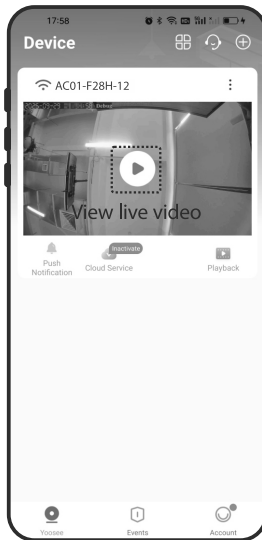
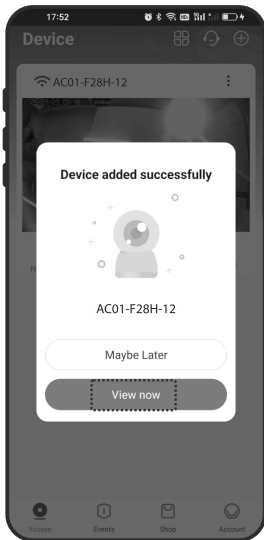
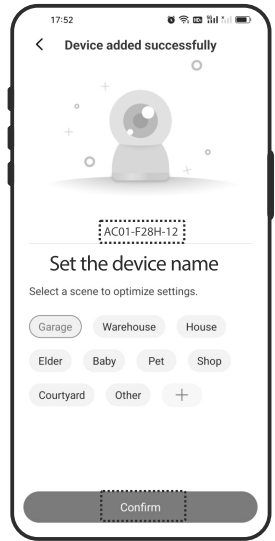
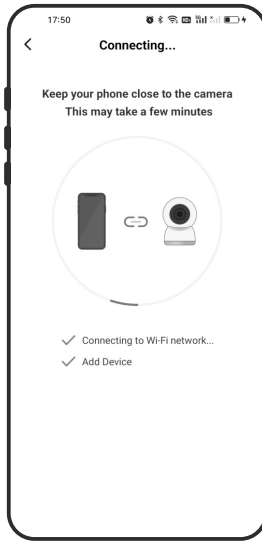
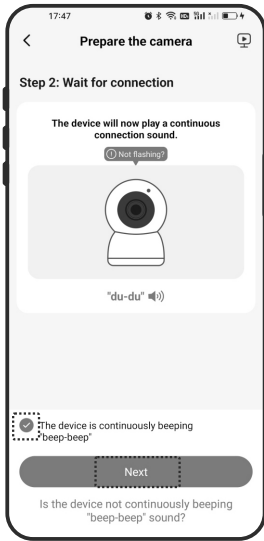



Step 4: Enable Events

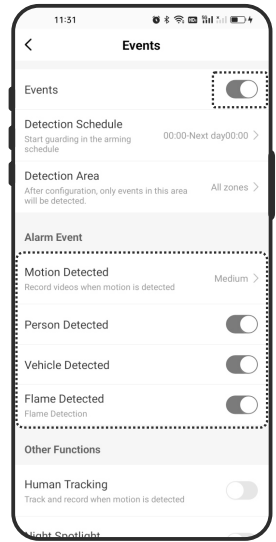
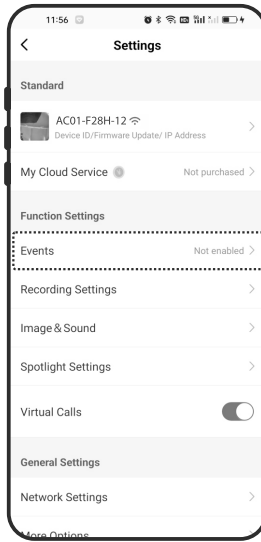
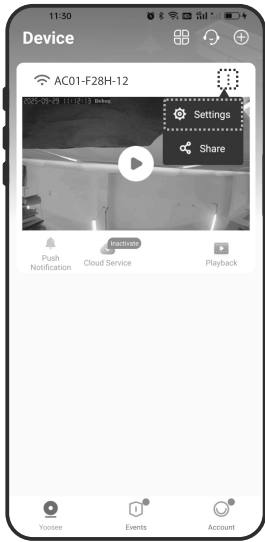

1. Click the  icon in the upper-right corner and select **Settings** from the dropdown menu.
2. In the Settings interface, locate the Function Settings section and tap **Events**.
3. Click the  icon to enable event functions. By default, motion detection, person detection, vehicle detection, and flame detection are enabled.

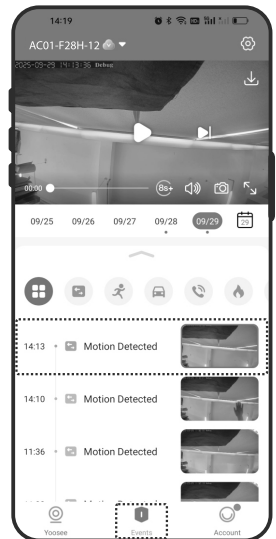
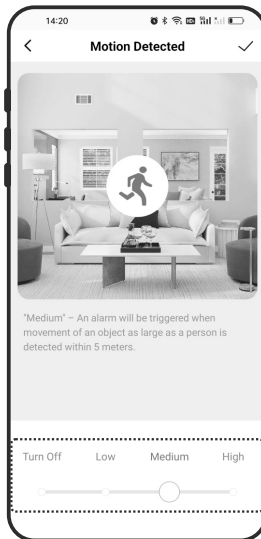
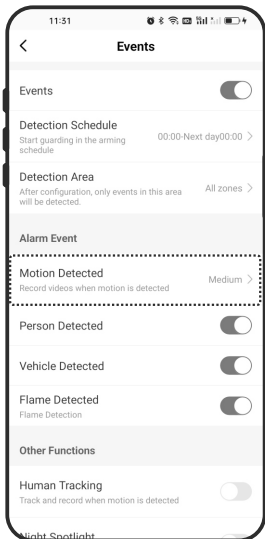

● Motion Detected

1. Record video when motion is detected in the frame; detection range can be customized.
2. There are three options available. Includes Turn Off, Low, Medium, and High. Select "Turn Off" to disable this feature.
3. Click the **Event** menu at the bottom to view related recorded videos. As shown below.



- After enabling the motion detection feature, it is triggered when a large target - such as a person - moves within the configured detection area.
- As shown below, an  alert icon will appear on the video interface. You can also click the  or  icons below the video interface to record or take a snapshot. Click the red alarm icon to dismiss this alert notification.

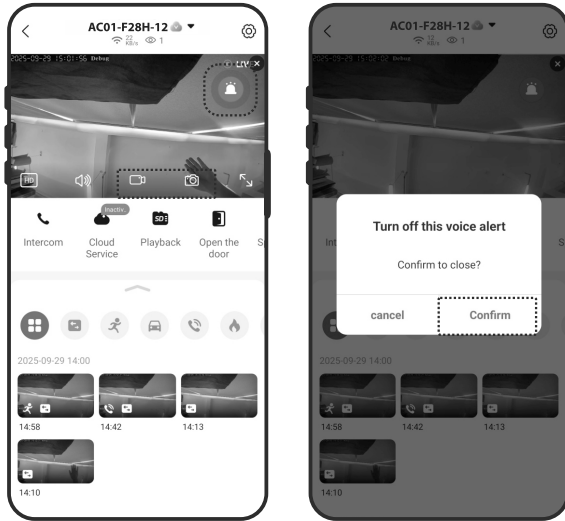

Note: When the app runs in the background or is in the Yoosee menu interface, if the device detects human activity, the following alarm interface will pop up. Click the bottom icon to perform the corresponding action. As shown in the figure below.

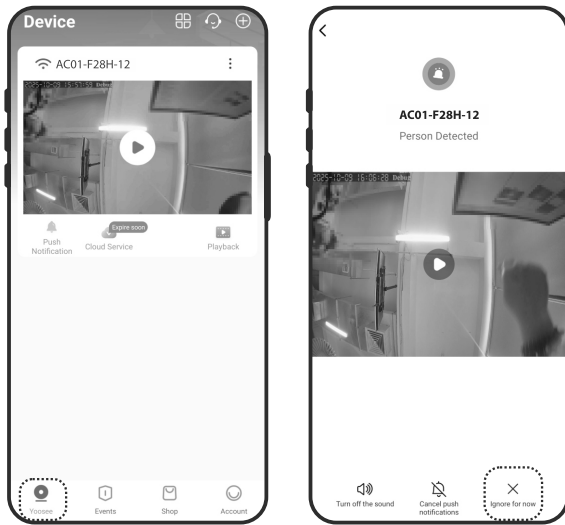

● **Person Detected**

Detects and highlights people in real time with on-screen bounding boxes. Actual detection range varies with lens FOV and mounting; confirm performance on-site in both day and IR night modes.

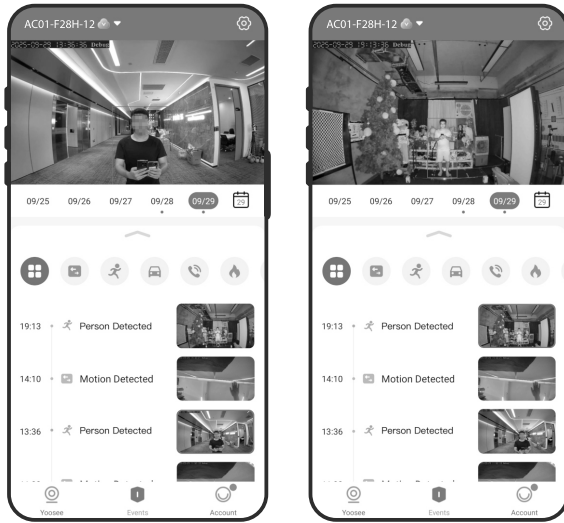

● **Vehicle Detected**

An intelligent algorithm capable of automatically identifying cars and trucks within video footage, then labeling and analyzing them. Recognition detection distance is highly dependent on camera angle, requiring field testing of night vision and daytime performance.



● Flame Detected

Flame detection: Uses color, flicker frequency, and shape variation to flag suspected flames. Adjustable sensitivity and minimum area; triggers event/notification.



Disclaimer: For supplementary use only; not a replacement for code - compliant fire detection.

● Video Intercom

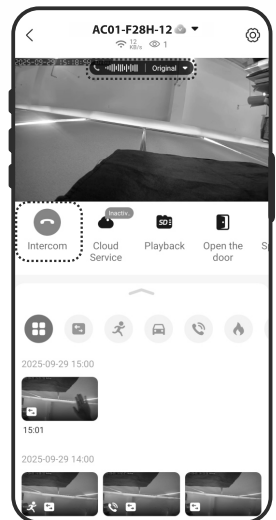
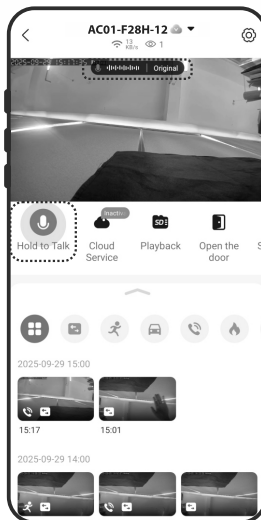
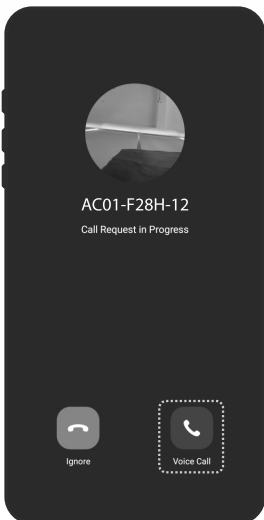
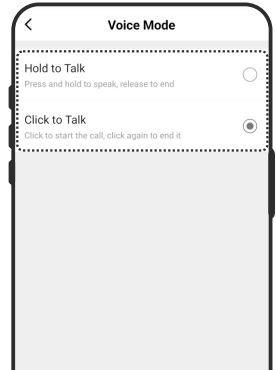
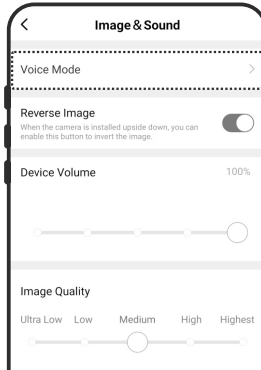
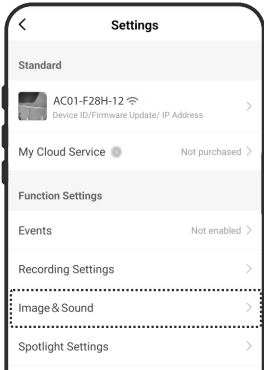
1. In **Settings**, go to **Image & Sound > Voice Mode**, and select a voice mode.
2. When someone presses the AC01-F28H-12 doorbell, the app shows the call screen.
3. If the app is in the foreground on the Home screen, the call screen opens directly; otherwise, you'll receive a push notification - tap it to open the call screen.
4. The call screen layout varies by voice mode. See the examples below.



● Remote Door Unlocking

1. Tap button  on the app's main interface to enter the live video interface.
2. Then tap the  icon to remotely unlock the door. The device will voice prompt "Door opened" and the app will display a notification.

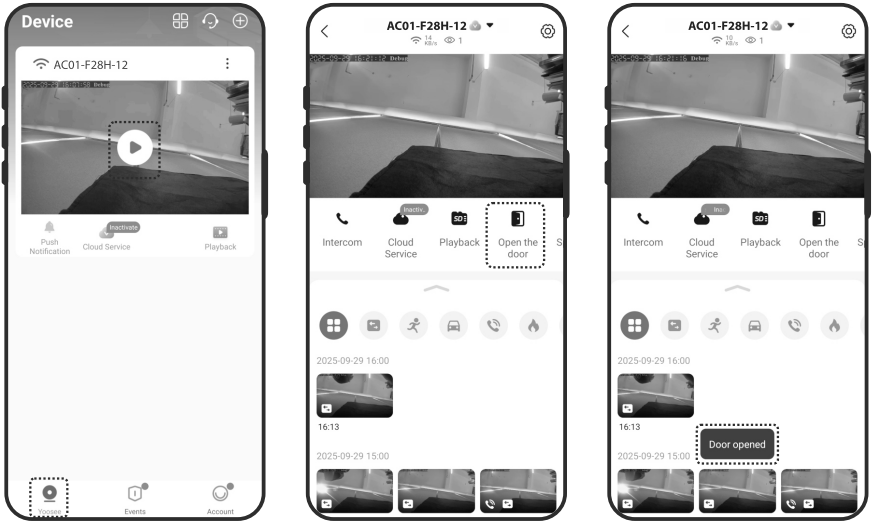

● Delete Device

1. Click the  icon in the upper-right corner and select **Settings** from the dropdown menu.
2. In the Settings interface, scroll to the very bottom and tap **Delete Device**.
3. Then click **Delete** in the pop-up window.

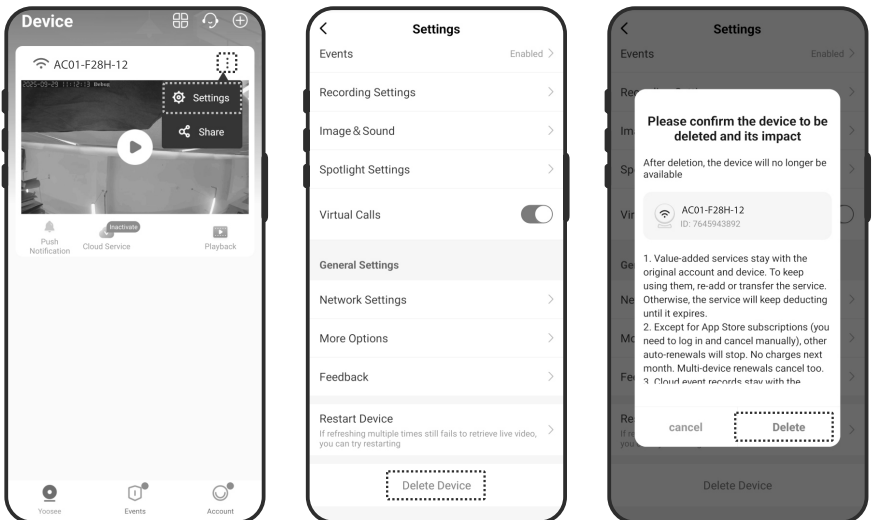

When removing a device:

- 1) Remove the device from the app. The intercom module will beep once.
- 2) Wait for the module to restart. It will beep three times (beep-beep-beep).
- 3) After the three beeps, disconnect the device's power.

To re-add the device:

- 1) On the device, navigate to **System > Video Intercom Parameters > Reset**.
- 2) Wait for the reset to complete.
- 3) Scan the device's QR code in the app to bind it again.

Important: Do not disconnect power before hearing the three-beep restart tone, otherwise the module may not reset properly.

● Reconfigure the intercom module's Wi-Fi

Note: This process only configures the Wi-Fi for the intercom module and does not configure the Wi-Fi for the AC01-F28H-12 terminal itself.

1. Click the  icon in the upper-right corner and select **Settings** from the dropdown menu.
2. Click the **Device Name** to enter the **Device Information** interface. You can view the device's IP address.
3. Tap **Network Settings** in the settings interface to modify the Wi-Fi configuration for the intercom module.
4. Reselect the Wi-Fi network you wish to connect to, enter the password, and click **Confirm**.
5. Once connected, the IP address on the device information screen will update to the new address.

